



AVIONICS ENGINEERING SERVICES

AIU

AUTOPILOT INTERFACE UNIT

The AES Autopilot Interface Unit (AIU) was designed to integrate the Honeywell FZ-500 Flight Director with the Honeywell SP-50 or the Bendix PB-20 autopilot in various types of aircraft.

The AIU allows the flight crew to operate the autopilot as an integrated system by flight director mode selection. No longer does the crew have to select two mode selection functions on both the flight director and the autopilot and then have the flight director command one bank angle and the autopilot create a different bank angle. With the AIU, only the flight director mode needs to be selected and the autopilot follows. The cockpit work load is reduced and the confusion is eliminated.

The addition of the AIU provides integrated flight director / autopilot lateral mode coupling of heading, VOR / LOC, and Long Range Navigation data. Vertical modes are Altitude Hold, Altitude Preselect, Vertical Speed, Indicated Airspeed and Mach Hold. Some installations with optional peripheral equipment can incorporate vertical command wheels and / or vertical navigation.

The installation of the AIU is the most economical way to have state of the art Flight Director / Autopilot integration for GII, GIIB, B727-100, P3-B and other aircraft.

There are many possible scenarios for ways to incorporate an AIU into a given aircraft. The following data sheets depict a few of the combinations of systems that may be designed to fit a particular aircraft requirement.

To insure the proper interface of the AIU to the existing Autopilot System, it is the aircraft owner / operators responsibility to verify the Autopilot has been tested and performs to the latest factory standards and contains the latest performance modifications.

AIU SYSTEM 1

(See Following Sheet)

Interfaced with FZ-500, SP-50 and AZ-242
with electromechanical instrumentation.

Provided Equipment

89-7007-X	Autopilot Interface Unit
-----------	--------------------------

Other Equipment Required

SP-50	Autopilot
FZ-500	Flight Director
AZ-242	Air Data Computer
AL-285	Altitude Preselect
CD-125	Air Data Command Display
Couple 1 / Couple 2	Switching Unit

AUTOPILOT INTERFACE UNIT WITH ELECTROMECHANICAL INSTRUMENTS AND AZ-242 ADC

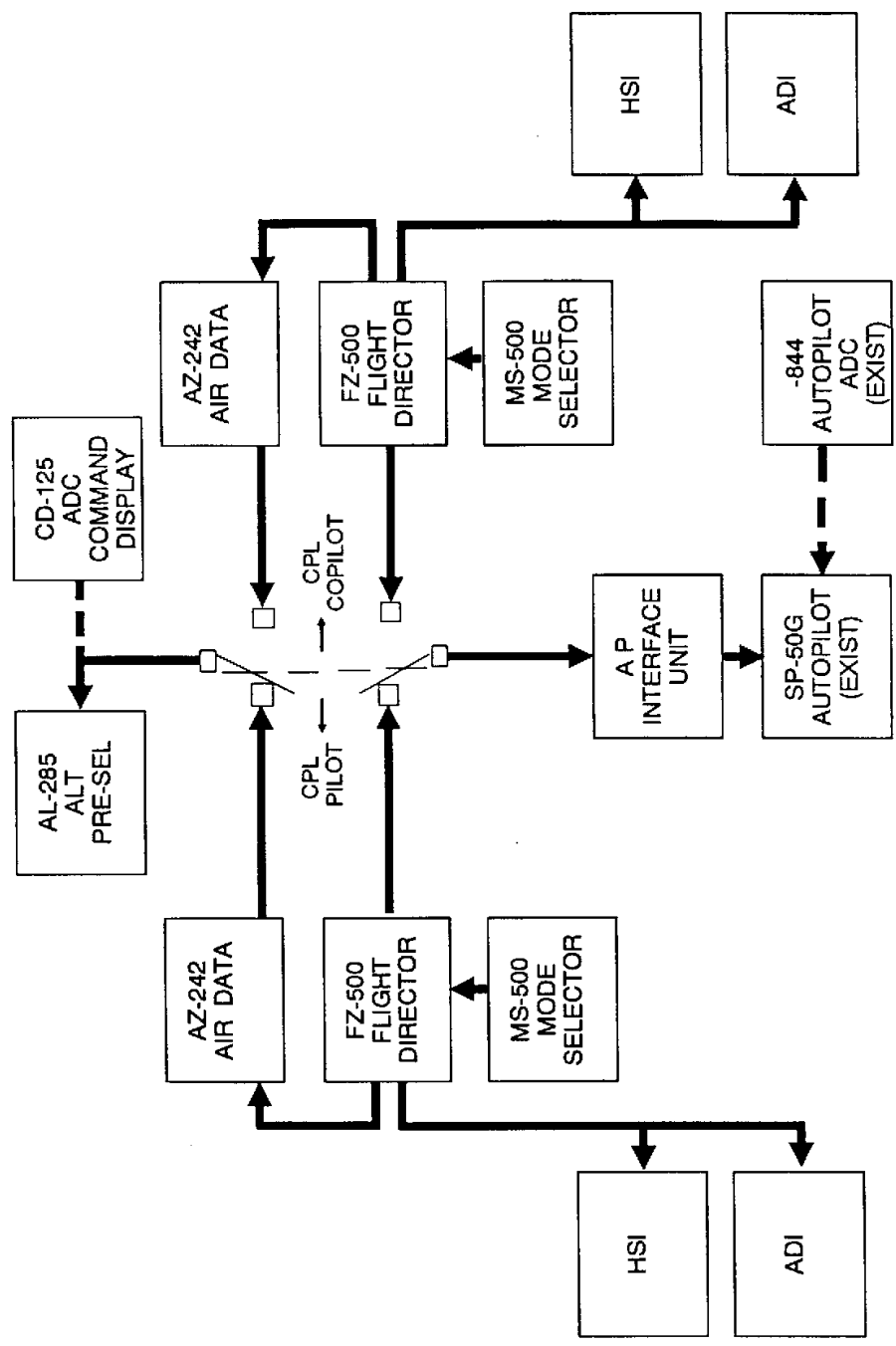

SYSTEM 1

AIU SYSTEM 2

(See Following Sheet)

Interfaced with FZ-500, SP-50 and AZ-800
with electromechanical instrumentation.

Provided Equipment

89-7007-X	Autopilot Interface Unit
-----------	--------------------------

Other Equipment Required

SP-50	Autopilot
FZ-500	Flight Director
AZ-800	Air Data Computer
AL-801	Altitude Preselect
CD-125	Air Data Command Display
Couple 1 / Couple 2	Switching Unit

Optional Features

1. VN-801 Vertical Navigation (replaces AI-801)
2. Vertical Command Wheel

AUTOPILOT INTERFACE UNIT WITH ELECTROMECHANICAL INSTRUMENTS AND AZ-800 ADC

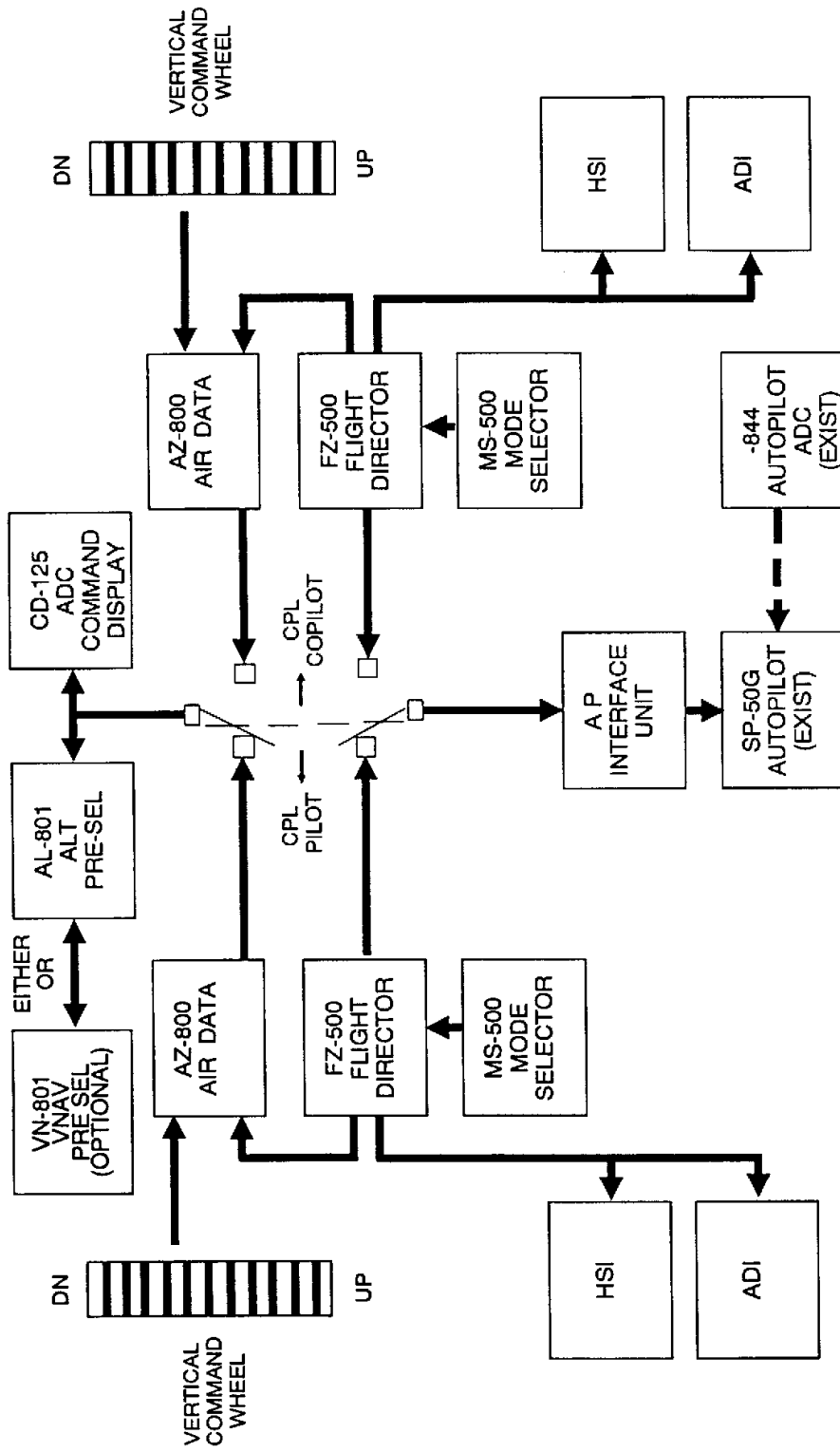

AIU SYSTEM 3

(See Following Sheet)

Interfaced with FZ-500, SP-50 and AZ-242
with EFIS instrumentation.

Provided Equipment

89-7007-X

Autopilot Interface Unit

Other Equipment Required

SP-50

Autopilot

FZ-500

Flight Director

AZ-242

Air Data Computer

AL-285

Altitude Preselect

Couple 1 / Couple 2

Switching Unit

AUTOPILOT INTERFACE UNIT WITH ELECTRONIC FLIGHT INSTRUMENT SYSTEM AND AZ-242 ADC

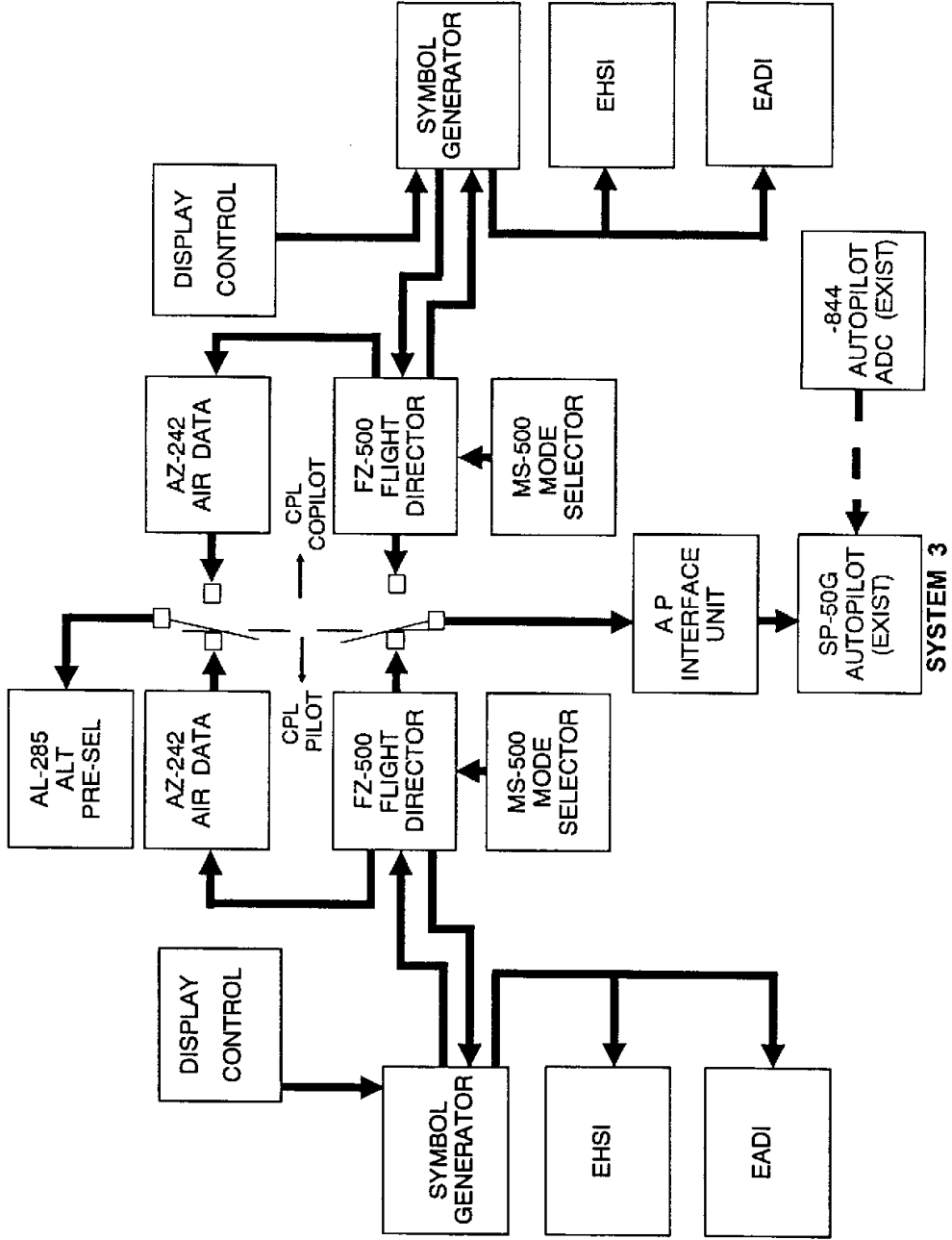

AIU SYSTEM 4

(See Following Sheet)

Interfaced with FZ-500, SP-50 and AZ-800
with EFIS instrumentation.

Provided Equipment

89-7007-X	Autopilot Interface Unit
-----------	--------------------------

Other Equipment Required

SP-50	Autopilot
FZ-500	Flight Director
AZ-800	Air Data Computer
AL-801	Altitude Preselect
Couple 1 / Couple 2	Switching Unit

Optional Features

1. VN-801 Vertical Navigation (replaces AI-801)
2. Vertical Command Wheel

AUTOPILOT INTERFACE UNIT WITH ELECTRONIC FLIGHT INSTRUMENT SYSTEM AND AZ-800 ADC

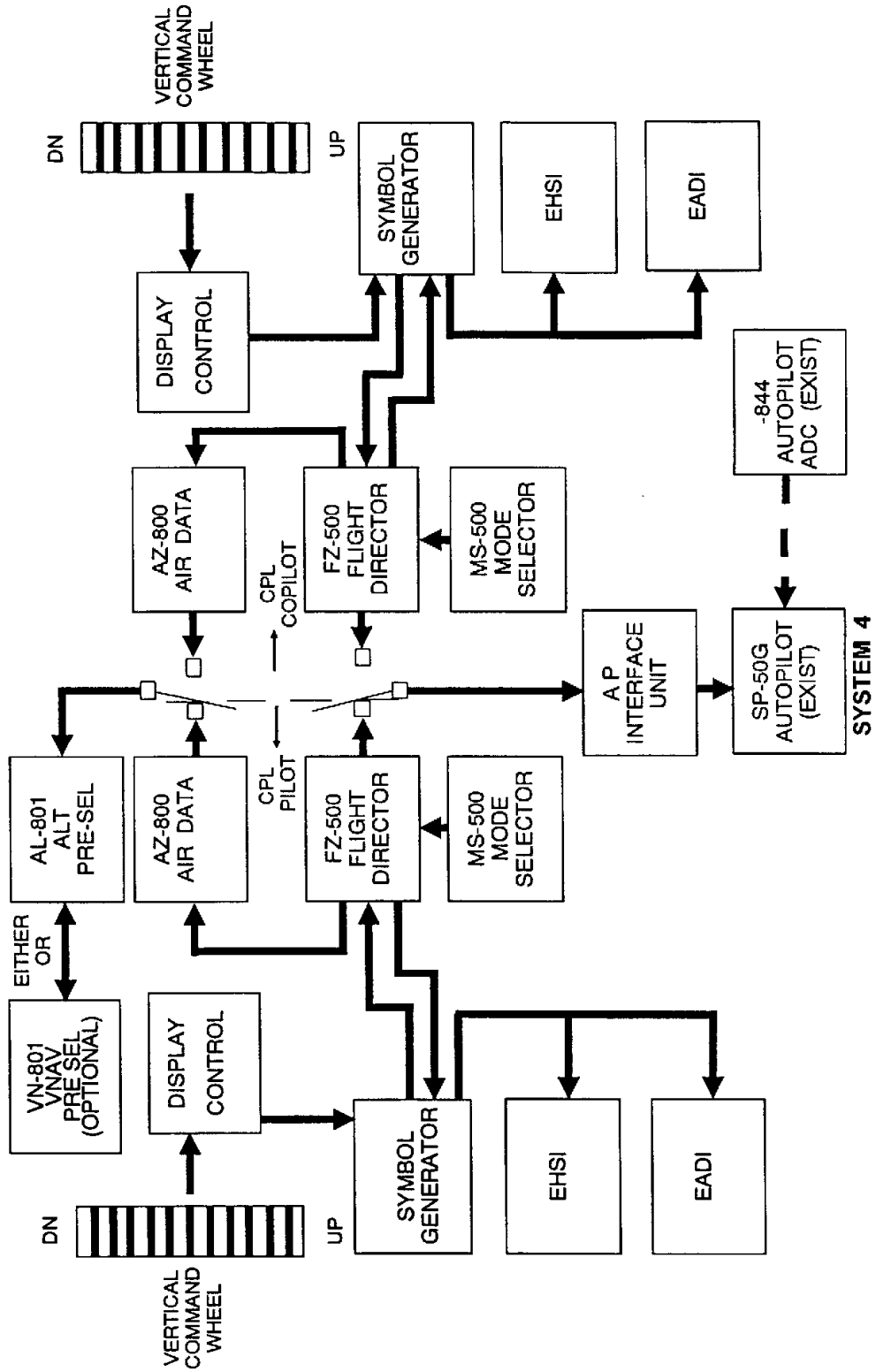

BLOCK DIAGRAM - AUTOPILOT INTERFACE UNIT (AIU)
FZ-500, SP-500 AUTOPILOT

- OPERATIONAL SUMMARY**
1. AUTOPILOT ENGAGED WITH NO FLIGHT DIRECTOR MODES SELECTED. NORMAL A/P PITCH & TURN HOBB OPERATOR.
 2. SELECTION OF HOLD TO LATERAL MODE ENABLES AIU TO PROCESS ROLL COMMANDS FROM FZ-500 AND ROUTE TO A/P HEADING CHANNEL INPUT.
 3. SELECTION OF HOLD TO PITCH MODES ENABLES AIU TO PROCESS PITCH COMMANDS FROM FZ-500 AND ROUTE TO A/P 1/5 COMMAND INPUT.
 4. MOVING A/P PITCH WHEEL CLEARS A.I. VS. WS, MACH, APP CAPT, ALT PRESEL, CAPT, DOES NOT CLEAR ALT PRESEL, APP, OR APP ARM.
 5. MOVING A/P TURN HOBB CLEARS ALL LATERAL MODES.
 6. DURING AIU COMPLET OPERATIONS, THE A/P PITCH SELECTOR KNOB AND A/P NAV SELECTOR SWITCH ARE DISABLED, AS IS THE A/P-505 SELECT SWITCH/ SOLENOID.
 7. IN THE EVENT OF AIU FAILURE, THE UNIT ALLOWING CONTROL TO RETURN TO BASIC A/P OPERATION. THE "AIU FAIL" ANNUNCIATOR WILL LIGHT. PULL THE AIU DC CIRCUIT BREAKER TO DISABLE THE UNIT. ALL A/P CONTROLS & MODES WILL OPERATE NORMALLY.
 8. SINGLE SYSTEM OPERATION ILLUSTRATED FOR "COUPLED-1" CONFIGURATION. OPERATOR'S CHOICE FOR 2, A.I.S. OR SWITCH SIGNALS FROM FZ-500 WITH COUPLED-2 RELAY LOGIC.

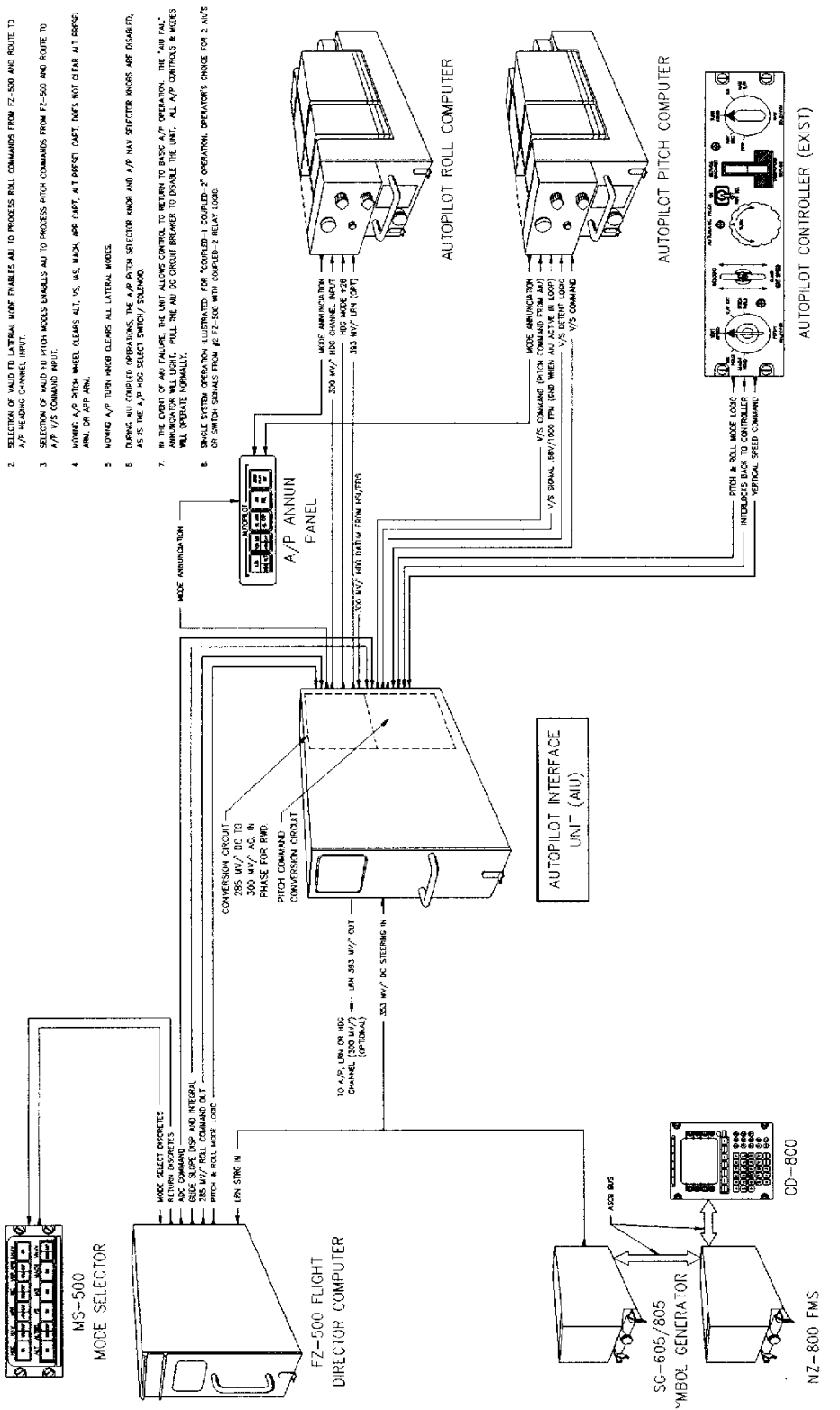

SPERRY FLIGHT MANAGEMENT SYSTEM

REV.	DATE	DESCRIPTION	BY	CHECKED	APPROVALS	DATE	STOCK SIZE	MATERIAL	SPEC./ROOM	NOTE
1	10/15/68	REVISED TO SHOW NEW WIRING	J. N. GOSWAMI	J. N. GOSWAMI	W. J. GOSWAMI	10/15/68	100	ALUMINUM ENGINEERING SERVICES	100	SEE BLOCK DIAGRAM - AUTOPILOT INTERFACE UNIT (AIU)
2	11/10/68	REVISED TO SHOW NEW WIRING	J. N. GOSWAMI	J. N. GOSWAMI	W. J. GOSWAMI	11/10/68	100	ALUMINUM ENGINEERING SERVICES	100	SEE BLOCK DIAGRAM - AUTOPILOT INTERFACE UNIT (AIU)
3	12/10/68	REVISED TO SHOW NEW WIRING	J. N. GOSWAMI	J. N. GOSWAMI	W. J. GOSWAMI	12/10/68	100	ALUMINUM ENGINEERING SERVICES	100	SEE BLOCK DIAGRAM - AUTOPILOT INTERFACE UNIT (AIU)
4	1/10/69	REVISED TO SHOW NEW WIRING	J. N. GOSWAMI	J. N. GOSWAMI	W. J. GOSWAMI	1/10/69	100	ALUMINUM ENGINEERING SERVICES	100	SEE BLOCK DIAGRAM - AUTOPILOT INTERFACE UNIT (AIU)
5	2/10/69	REVISED TO SHOW NEW WIRING	J. N. GOSWAMI	J. N. GOSWAMI	W. J. GOSWAMI	2/10/69	100	ALUMINUM ENGINEERING SERVICES	100	SEE BLOCK DIAGRAM - AUTOPILOT INTERFACE UNIT (AIU)
6	3/10/69	REVISED TO SHOW NEW WIRING	J. N. GOSWAMI	J. N. GOSWAMI	W. J. GOSWAMI	3/10/69	100	ALUMINUM ENGINEERING SERVICES	100	SEE BLOCK DIAGRAM - AUTOPILOT INTERFACE UNIT (AIU)
7	4/10/69	REVISED TO SHOW NEW WIRING	J. N. GOSWAMI	J. N. GOSWAMI	W. J. GOSWAMI	4/10/69	100	ALUMINUM ENGINEERING SERVICES	100	SEE BLOCK DIAGRAM - AUTOPILOT INTERFACE UNIT (AIU)
8	5/10/69	REVISED TO SHOW NEW WIRING	J. N. GOSWAMI	J. N. GOSWAMI	W. J. GOSWAMI	5/10/69	100	ALUMINUM ENGINEERING SERVICES	100	SEE BLOCK DIAGRAM - AUTOPILOT INTERFACE UNIT (AIU)
9	6/10/69	REVISED TO SHOW NEW WIRING	J. N. GOSWAMI	J. N. GOSWAMI	W. J. GOSWAMI	6/10/69	100	ALUMINUM ENGINEERING SERVICES	100	SEE BLOCK DIAGRAM - AUTOPILOT INTERFACE UNIT (AIU)
10	7/10/69	REVISED TO SHOW NEW WIRING	J. N. GOSWAMI	J. N. GOSWAMI	W. J. GOSWAMI	7/10/69	100	ALUMINUM ENGINEERING SERVICES	100	SEE BLOCK DIAGRAM - AUTOPILOT INTERFACE UNIT (AIU)
11	8/10/69	REVISED TO SHOW NEW WIRING	J. N. GOSWAMI	J. N. GOSWAMI	W. J. GOSWAMI	8/10/69	100	ALUMINUM ENGINEERING SERVICES	100	SEE BLOCK DIAGRAM - AUTOPILOT INTERFACE UNIT (AIU)
12	9/10/69	REVISED TO SHOW NEW WIRING	J. N. GOSWAMI	J. N. GOSWAMI	W. J. GOSWAMI	9/10/69	100	ALUMINUM ENGINEERING SERVICES	100	SEE BLOCK DIAGRAM - AUTOPILOT INTERFACE UNIT (AIU)
13	10/10/69	REVISED TO SHOW NEW WIRING	J. N. GOSWAMI	J. N. GOSWAMI	W. J. GOSWAMI	10/10/69	100	ALUMINUM ENGINEERING SERVICES	100	SEE BLOCK DIAGRAM - AUTOPILOT INTERFACE UNIT (AIU)
14	11/10/69	REVISED TO SHOW NEW WIRING	J. N. GOSWAMI	J. N. GOSWAMI	W. J. GOSWAMI	11/10/69	100	ALUMINUM ENGINEERING SERVICES	100	SEE BLOCK DIAGRAM - AUTOPILOT INTERFACE UNIT (AIU)
15	12/10/69	REVISED TO SHOW NEW WIRING	J. N. GOSWAMI	J. N. GOSWAMI	W. J. GOSWAMI	12/10/69	100	ALUMINUM ENGINEERING SERVICES	100	SEE BLOCK DIAGRAM - AUTOPILOT INTERFACE UNIT (AIU)
16	1/10/70	REVISED TO SHOW NEW WIRING	J. N. GOSWAMI	J. N. GOSWAMI	W. J. GOSWAMI	1/10/70	100	ALUMINUM ENGINEERING SERVICES	100	SEE BLOCK DIAGRAM - AUTOPILOT INTERFACE UNIT (AIU)
17	2/10/70	REVISED TO SHOW NEW WIRING	J. N. GOSWAMI	J. N. GOSWAMI	W. J. GOSWAMI	2/10/70	100	ALUMINUM ENGINEERING SERVICES	100	SEE BLOCK DIAGRAM - AUTOPILOT INTERFACE UNIT (AIU)
18	3/10/70	REVISED TO SHOW NEW WIRING	J. N. GOSWAMI	J. N. GOSWAMI	W. J. GOSWAMI	3/10/70	100	ALUMINUM ENGINEERING SERVICES	100	SEE BLOCK DIAGRAM - AUTOPILOT INTERFACE UNIT (AIU)
19	4/10/70	REVISED TO SHOW NEW WIRING	J. N. GOSWAMI	J. N. GOSWAMI	W. J. GOSWAMI	4/10/70	100	ALUMINUM ENGINEERING SERVICES	100	SEE BLOCK DIAGRAM - AUTOPILOT INTERFACE UNIT (AIU)
20	5/10/70	REVISED TO SHOW NEW WIRING	J. N. GOSWAMI	J. N. GOSWAMI	W. J. GOSWAMI	5/10/70	100	ALUMINUM ENGINEERING SERVICES	100	SEE BLOCK DIAGRAM - AUTOPILOT INTERFACE UNIT (AIU)
21	6/10/70	REVISED TO SHOW NEW WIRING	J. N. GOSWAMI	J. N. GOSWAMI	W. J. GOSWAMI	6/10/70	100	ALUMINUM ENGINEERING SERVICES	100	SEE BLOCK DIAGRAM - AUTOPILOT INTERFACE UNIT (AIU)
22	7/10/70	REVISED TO SHOW NEW WIRING	J. N. GOSWAMI	J. N. GOSWAMI	W. J. GOSWAMI	7/10/70	100	ALUMINUM ENGINEERING SERVICES	100	SEE BLOCK DIAGRAM - AUTOPILOT INTERFACE UNIT (AIU)
23	8/10/70	REVISED TO SHOW NEW WIRING	J. N. GOSWAMI	J. N. GOSWAMI	W. J. GOSWAMI	8/10/70	100	ALUMINUM ENGINEERING SERVICES	100	SEE BLOCK DIAGRAM - AUTOPILOT INTERFACE UNIT (AIU)
24	9/10/70	REVISED TO SHOW NEW WIRING	J. N. GOSWAMI	J. N. GOSWAMI	W. J. GOSWAMI	9/10/70	100	ALUMINUM ENGINEERING SERVICES	100	SEE BLOCK DIAGRAM - AUTOPILOT INTERFACE UNIT (AIU)
25	10/10/70	REVISED TO SHOW NEW WIRING	J. N. GOSWAMI	J. N. GOSWAMI	W. J. GOSWAMI	10/10/70	100	ALUMINUM ENGINEERING SERVICES	100	SEE BLOCK DIAGRAM - AUTOPILOT INTERFACE UNIT (AIU)
26	11/10/70	REVISED TO SHOW NEW WIRING	J. N. GOSWAMI	J. N. GOSWAMI	W. J. GOSWAMI	11/10/70	100	ALUMINUM ENGINEERING SERVICES	100	SEE BLOCK DIAGRAM - AUTOPILOT INTERFACE UNIT (AIU)
27	12/10/70	REVISED TO SHOW NEW WIRING	J. N. GOSWAMI	J. N. GOSWAMI	W. J. GOSWAMI	12/10/70	100	ALUMINUM ENGINEERING SERVICES	100	SEE BLOCK DIAGRAM - AUTOPILOT INTERFACE UNIT (AIU)
28	1/10/71	REVISED TO SHOW NEW WIRING	J. N. GOSWAMI	J. N. GOSWAMI	W. J. GOSWAMI	1/10/71	100	ALUMINUM ENGINEERING SERVICES	100	SEE BLOCK DIAGRAM - AUTOPILOT INTERFACE UNIT (AIU)
29	2/10/71	REVISED TO SHOW NEW WIRING	J. N. GOSWAMI	J. N. GOSWAMI	W. J. GOSWAMI	2/10/71	100	ALUMINUM ENGINEERING SERVICES	100	SEE BLOCK DIAGRAM - AUTOPILOT INTERFACE UNIT (AIU)
30	3/10/71	REVISED TO SHOW NEW WIRING	J. N. GOSWAMI	J. N. GOSWAMI	W. J. GOSWAMI	3/10/71	100	ALUMINUM ENGINEERING SERVICES	100	SEE BLOCK DIAGRAM - AUTOPILOT INTERFACE UNIT (AIU)
31	4/10/71	REVISED TO SHOW NEW WIRING	J. N. GOSWAMI	J. N. GOSWAMI	W. J. GOSWAMI	4/10/71	100	ALUMINUM ENGINEERING SERVICES	100	SEE BLOCK DIAGRAM - AUTOPILOT INTERFACE UNIT (AIU)
32	5/10/71	REVISED TO SHOW NEW WIRING	J. N. GOSWAMI	J. N. GOSWAMI	W. J. GOSWAMI	5/10/71	100	ALUMINUM ENGINEERING SERVICES	100	SEE BLOCK DIAGRAM - AUTOPILOT INTERFACE UNIT (AIU)
33	6/10/71	REVISED TO SHOW NEW WIRING	J. N. GOSWAMI	J. N. GOSWAMI	W. J. GOSWAMI	6/10/71	100	ALUMINUM ENGINEERING SERVICES	100	SEE BLOCK DIAGRAM - AUTOPILOT INTERFACE UNIT (AIU)
34	7/10/71	REVISED TO SHOW NEW WIRING	J. N. GOSWAMI	J. N. GOSWAMI	W. J. GOSWAMI	7/10/71	100	ALUMINUM ENGINEERING SERVICES	100	SEE BLOCK DIAGRAM - AUTOPILOT INTERFACE UNIT (AIU)
35	8/10/71	REVISED TO SHOW NEW WIRING	J. N. GOSWAMI	J. N. GOSWAMI	W. J. GOSWAMI	8/10/71	100	ALUMINUM ENGINEERING SERVICES	100	SEE BLOCK DIAGRAM - AUTOPILOT INTERFACE UNIT (AIU)
36	9/10/71	REVISED TO SHOW NEW WIRING	J. N. GOSWAMI	J. N. GOSWAMI	W. J. GOSWAMI	9/10/71	100	ALUMINUM ENGINEERING SERVICES	100	SEE BLOCK DIAGRAM - AUTOPILOT INTERFACE UNIT (AIU)
37	10/10/71	REVISED TO SHOW NEW WIRING	J. N. GOSWAMI	J. N. GOSWAMI	W. J. GOSWAMI	10/10/71	100	ALUMINUM ENGINEERING SERVICES	100	SEE BLOCK DIAGRAM - AUTOPILOT INTERFACE UNIT (AIU)
38	11/10/71	REVISED TO SHOW NEW WIRING	J. N. GOSWAMI	J. N. GOSWAMI	W. J. GOSWAMI	11/10/71	100	ALUMINUM ENGINEERING SERVICES	100	SEE BLOCK DIAGRAM - AUTOPILOT INTERFACE UNIT (AIU)
39	12/10/71	REVISED TO SHOW NEW WIRING	J. N. GOSWAMI	J. N. GOSWAMI	W. J. GOSWAMI	12/10/71	100	ALUMINUM ENGINEERING SERVICES	100	SEE BLOCK DIAGRAM - AUTOPILOT INTERFACE UNIT (AIU)
40	1/10/72	REVISED TO SHOW NEW WIRING	J. N. GOSWAMI	J. N. GOSWAMI	W. J. GOSWAMI	1/10/72	100	ALUMINUM ENGINEERING SERVICES	100	SEE BLOCK DIAGRAM - AUTOPILOT INTERFACE UNIT (AIU)
41	2/10/72	REVISED TO SHOW NEW WIRING	J. N. GOSWAMI	J. N. GOSWAMI	W. J. GOSWAMI	2/10/72	100	ALUMINUM ENGINEERING SERVICES	100	SEE BLOCK DIAGRAM - AUTOPILOT INTERFACE UNIT (AIU)
42	3/10/72	REVISED TO SHOW NEW WIRING	J. N. GOSWAMI	J. N. GOSWAMI	W. J. GOSWAMI	3/10/72	100	ALUMINUM ENGINEERING SERVICES	100	SEE BLOCK DIAGRAM - AUTOPILOT INTERFACE UNIT (AIU)
43	4/10/72	REVISED TO SHOW NEW WIRING	J. N. GOSWAMI	J. N. GOSWAMI	W. J. GOSWAMI	4/10/72	100	ALUMINUM ENGINEERING SERVICES	100	SEE BLOCK DIAGRAM - AUTOPILOT INTERFACE UNIT (AIU)
44	5/10/72	REVISED TO SHOW NEW WIRING	J. N. GOSWAMI	J. N. GOSWAMI	W. J. GOSWAMI	5/10/72	100	ALUMINUM ENGINEERING SERVICES	100	SEE BLOCK DIAGRAM - AUTOPILOT INTERFACE UNIT (AIU)
45	6/10/72	REVISED TO SHOW NEW WIRING	J. N. GOSWAMI	J. N. GOSWAMI	W. J. GOSWAMI	6/10/72	100	ALUMINUM ENGINEERING SERVICES	100	SEE BLOCK DIAGRAM - AUTOPILOT INTERFACE UNIT (AIU)
46	7/10/72	REVISED TO SHOW NEW WIRING	J. N. GOSWAMI	J. N. GOSWAMI	W. J. GOSWAMI	7/10/72	100	ALUMINUM ENGINEERING SERVICES	100	SEE BLOCK DIAGRAM - AUTOPILOT INTERFACE UNIT (AIU)
47	8/10/72	REVISED TO SHOW NEW WIRING	J. N. GOSWAMI	J. N. GOSWAMI	W. J. GOSWAMI	8/10/72	100	ALUMINUM ENGINEERING SERVICES	100	SEE BLOCK DIAGRAM - AUTOPILOT INTERFACE UNIT (AIU)
48	9/10/72	REVISED TO SHOW NEW WIRING	J. N. GOSWAMI	J. N. GOSWAMI	W. J. GOSWAMI	9/10/72	100	ALUMINUM ENGINEERING SERVICES	100	SEE BLOCK DIAGRAM - AUTOPILOT INTERFACE UNIT (AIU)
49	10/10/72	REVISED TO SHOW NEW WIRING	J. N. GOSWAMI	J. N. GOSWAMI	W. J. GOSWAMI	10/10/72	100	ALUMINUM ENGINEERING SERVICES	100	SEE BLOCK DIAGRAM - AUTOPILOT INTERFACE UNIT (AIU)
50	11/10/72	REVISED TO SHOW NEW WIRING	J. N. GOSWAMI	J. N. GOSWAMI	W. J. GOSWAMI	11/10/72	100	ALUMINUM ENGINEERING SERVICES	100	SEE BLOCK DIAGRAM - AUTOPILOT INTERFACE UNIT (AIU)
51	12/10/72	REVISED TO SHOW NEW WIRING	J. N. GOSWAMI	J. N. GOSWAMI	W. J. GOSWAMI	12/10/72	100	ALUMINUM ENGINEERING SERVICES	100	SEE BLOCK DIAGRAM - AUTOPILOT INTERFACE UNIT (AIU)
52	1/10/73	REVISED TO SHOW NEW WIRING	J. N. GOSWAMI	J. N. GOSWAMI	W. J. GOSWAMI	1/10/73	100	ALUMINUM ENGINEERING SERVICES	100	SEE BLOCK DIAGRAM - AUTOPILOT INTERFACE UNIT (AIU)
53	2/10/73	REVISED TO SHOW NEW WIRING	J. N. GOSWAMI	J. N. GOSWAMI	W. J. GOSWAMI	2/10/73	100	ALUMINUM ENGINEERING SERVICES	100	SEE BLOCK DIAGRAM - AUTOPILOT INTERFACE UNIT (AIU)
54	3/10/73	REVISED TO SHOW NEW WIRING	J. N. GOSWAMI	J. N. GOSWAMI	W. J. GOSWAMI	3/10/73	100	ALUMINUM ENGINEERING SERVICES	100	SEE BLOCK DIAGRAM - AUTOPILOT INTERFACE UNIT (AIU)
55	4/10/73	REVISED TO SHOW NEW WIRING	J. N. GOSWAMI	J. N. GOSWAMI	W. J. GOSWAMI	4/10/73	100	ALUMINUM ENGINEERING SERVICES	100	SEE BLOCK DIAGRAM - AUTOPILOT INTERFACE UNIT (AIU)
56	5/10/73	REVISED TO SHOW NEW WIRING	J. N. GOSWAMI	J. N. GOSWAMI	W. J. GOSWAMI	5/10/73	100	ALUMINUM ENGINEERING SERVICES	100	SEE BLOCK DIAGRAM - AUTOPILOT INTERFACE UNIT (AIU)
57	6/10/73	REVISED TO SHOW NEW WIRING	J. N. GOSWAMI	J. N. GOSWAMI	W. J. GOSWAMI	6/10/73	100	ALUMINUM ENGINEERING SERVICES	100	SEE BLOCK DIAGRAM - AUTOPILOT INTERFACE UNIT (AIU)
58	7/10/73	REVISED TO SHOW NEW WIRING	J. N. GOSWAMI	J. N. GOSWAMI	W. J. GOSWAMI	7/10/73	100	ALUMINUM ENGINEERING SERVICES	100	SEE BLOCK DIAGRAM - AUTOPILOT INTERFACE UNIT (AIU)
59	8/10/73	REVISED TO SHOW NEW WIRING	J. N. GOSWAMI	J. N. GOSWAMI	W. J. GOSWAMI	8/10/73	100	ALUMINUM ENGINEERING SERVICES	100	SEE BLOCK DIAGRAM - AUTOPILOT INTERFACE UNIT (AIU)
60	9/10/73	REVISED TO SHOW NEW WIRING	J. N. GOSWAMI	J. N. GOSWAMI	W. J. GOSWAMI	9/10/73	100	ALUMINUM ENGINEERING SERVICES	100	SEE BLOCK DIAGRAM - AUTOPILOT INTERFACE UNIT (AIU)
61	10/10/73	REVISED TO SHOW NEW WIRING	J. N. GOSWAMI	J. N. GOSWAMI	W. J. GOSWAMI	10/10/73	100	ALUMINUM ENGINEERING SERVICES	100	SEE BLOCK DIAGRAM - AUTOPILOT INTERFACE UNIT (AIU)
62	11/10/73	REVISED TO SHOW NEW WIRING	J. N. GOSWAMI	J. N. GOSWAMI	W. J. GOSWAMI	11/10/73	100	ALUMINUM ENGINEERING SERVICES	100	SEE BLOCK DIAGRAM - AUTOPILOT INTERFACE UNIT (AIU)
63	12/10/73	REVISED TO SHOW NEW WIRING	J. N. GOSWAMI	J. N. GOSWAMI	W. J. GOSWAMI	12/10/73	100	ALUMINUM ENGINEERING SERVICES	100	SEE BLOCK DIAGRAM - AUTOPILOT INTERFACE UNIT (AIU)
64	1/10/74	REVISED TO SHOW NEW WIRING	J. N. GOSWAMI	J. N. GOSWAMI	W. J. GOSWAMI	1/10/74	100	ALUMINUM ENGINEERING SERVICES	100	SEE BLOCK DIAGRAM - AUTOPILOT INTERFACE UNIT (AIU)
65	2/10/74	REVISED TO SHOW NEW WIRING	J. N. GOSWAMI	J. N. GOSWAMI	W. J. GOSWAMI	2/10/74	100	ALUMINUM ENGINEERING SERVICES	100	SEE BLOCK DIAGRAM - AUTOPILOT INTERFACE UNIT (AIU)
66	3/10/74	REVISED TO SHOW NEW WIRING	J. N. GOSWAMI	J. N. GOSWAMI	W. J. GOSWAMI	3/10/74	100	ALUMINUM ENGINEERING SERVICES	100	SEE BLOCK DIAGRAM - AUTOPILOT INTERFACE UNIT (AIU)
67	4/10/74	REVISED TO SHOW NEW WIRING	J. N. GOSWAMI	J. N. GOSWAMI	W. J. GOSWAMI	4/10/74	100	ALUMINUM ENGINEERING SERVICES	100	SEE BLOCK DIAGRAM - AUTOPILOT INTERFACE UNIT (AIU)
68	5/10/74	REVISED TO SHOW NEW WIRING	J. N. GOSWAMI	J. N. GOSWAMI	W. J. GOSWAMI	5/10/74	100	ALUMINUM ENGINEERING SERVICES	100	SEE BLOCK DIAGRAM - AUTOPILOT INTERFACE UNIT (AIU)
69	6/10/74	REVISED TO SHOW NEW WIRING	J. N. GOSWAMI	J. N. GOSWAMI	W. J. GOSWAMI	6/10/74	100	ALUMINUM ENGINEERING SERVICES	100	SEE BLOCK DIAGRAM - AUTOPILOT INTERFACE UNIT (AIU)
70	7/10/74	REVISED TO SHOW NEW WIRING	J. N. GOSWAMI	J. N. GOSWAMI	W. J. GOSWAMI	7/10/74	100	ALUMINUM ENGINEERING SERVICES	100	SEE BLOCK DIAGRAM - AUTOPILOT INTERFACE UNIT (AIU)
71	8/10/74	REVISED TO SHOW NEW WIRING	J. N. GOSWAMI	J. N. GOSWAMI	W. J. GOSWAMI	8/10/74	100	ALUMINUM ENGINEERING SERVICES	100	SEE BLOCK DIAGRAM - AUTOPILOT INTERFACE UNIT (AIU)
72	9/10/74	REVISED TO SHOW NEW WIRING	J. N. GOSWAMI	J. N. GOSWAMI	W. J. GOSWAMI	9/10/74	100	ALUMINUM ENGINEERING SERVICES	100	SEE BLOCK DIAGRAM - AUTOPILOT INTERFACE UNIT (AIU)
73	10/10/74	REVISED TO SHOW NEW WIRING	J. N. GOSWAMI	J. N. GOSWAMI	W. J. GOSWAMI	10/10/74	100	ALUMINUM ENGINEERING SERVICES	100	SEE BLOCK DIAGRAM - AUTOPILOT INTERFACE UNIT (AIU)
74	11/10/74	REVISED TO SHOW NEW WIRING	J. N. GOSWAMI	J. N. GOSWAMI	W. J. GOSWAMI	11/10/74	100	ALUMINUM ENGINEERING SERVICES	100	SEE BLOCK DIAGRAM - AUTOPILOT INTERFACE UNIT (AIU)
75	12/10/74	REVISED TO SHOW NEW WIRING	J. N. GOSWAMI	J. N. GOSWAMI	W. J. GOSWAMI	12/10/74	100	ALUMINUM ENGINEERING SERVICES	100	SEE BLOCK DIAGRAM - AUTOPILOT INTERFACE UNIT (AIU)
76	1/10/75	REVISED TO SHOW NEW WIRING	J. N. GOSWAMI							

